

Delivery address: Mackenrodtstraße 14,
36039 Fulda, Germany
Postal address: 36035 Fulda, Germany
Phone: +49 661 6003-0
Fax: +49 661 6003-607
E-mail: mail@jumo.net
Internet: www.jumo.net

JUMO House
Temple Bank, Riverway
Harlow, Essex CM 20 2TT, UK
Phone: +44 1279 635533
Fax: +44 1279 635262
E-mail: sales@jumo.co.uk
Internet: www.jumo.co.uk

885 Fox Chase, Suite 103
Coatesville PA 19320, USA
Phone: 610-380-8002
1-800-554-JUMO
Fax: 610-380-8009
E-mail: info@JumoUSA.com
Internet: www.JumoUSA.com



Thyristor power switches

- load currents 25A and 50A (max.)
- load voltages 265V and 530V (max.)
- control voltage 4 – 32V DC
- UL approval



Brief description

Thyristor power switches are used for the contact-free switching of a.c. loads. A typical application is the switching of resistive-inductive loads at high switching rates, especially in the industrial sector, such as in the plastics packaging industry, in HVAC engineering and in the construction of industrial furnaces.

The control and power sections are electrically isolated by optocouplers.

The control signal range is compatible with the logic outputs of JUMO controllers.

The power section operates as a zero-voltage switch, which means that it always switches when the voltage passes through zero, irrespective of the instant of the signal change.

This prevents the generation of interference voltages. A varistor is integrated on the output side as a protection against voltage spikes.

The input status is indicated by an LED.



TYA 432-45/50 (25), 530 (265)

Technical data

Load circuit

Type	TYA 432-45/25, 265	TYA 432-45/50, 530
Load voltage	24 – 265V _{rms}	42 – 530V _{rms}
Load current (maximum)	25A _{rms}	50A _{rms}
Load current (minimum)	150mA _{rms}	
Fuse load integral limit $I^2 \cdot t$ (t = 10msec)	$\leq 310A^2 \cdot \text{sec}$	$\leq 1800A^2 \cdot \text{sec}$
Frequency	45 – 65Hz	
Peak off-state voltage	$\geq 650V_{pk}$	$\geq 1200V_{pk}$
Leakage current	$\leq 3mA$	
cos φ (p.f.)	>0.5 at 230V _{rms}	>0.5 at 230V _{rms}

Control

Control signal range	4 – 32V DC
Switch-on voltage	$\leq 2.75V$ DC for TYA 432-45/25,265 $\leq 3.75V$ DC for TYA 432-45/50,530
Switch-off voltage	$\geq 2V$ DC
Input current	$\leq 10mA$ at 32V DC
Response delay	$\leq 0.5 \cdot \text{cycle length}$

General data

Operating mode	zero-crossing switching
Electrical isolation	by optocoupler between control and power section; insulation voltage $\geq 4\text{ kV}$
Thermal resistance junction-case	0.8 °C/W for TYA 432-45/25, 265 0.5 °C/W for TYA 432-45/50, 530
Permissible ambient temperature	-20 to +70°C
Storage temperature	-40 to +100°C
Electrical connection	via screw terminals (load: $\square 16\text{ mm}^2$ max. / control: $\square 2.5\text{ mm}^2$ max.)
Electromagnetic compatibility	EN 50 082-1 EN 50 081-2
Electrical safety	overvoltage category III pollution degree 3 (external)
Housing	Noryl 6FN 1
Enclosure protection	IP20
Weight	60g

Derating tables

The maximum thermal resistance between the baseplate of the thyristor power switch and the environment $R_{(thSA)}$ is determined as a function of the load currents and the different ambient temperatures. The matrix below has been provided for this purpose. The power loss at a given nominal current can also be taken from this matrix.

Example:

Current $I = 15\text{ A}$ resistive load

$T_A = 40^\circ\text{C}$ (measured during operation, with the power switch built into a switchgear cabinet)

Selected thyristor power switch: TYA 432-45/25, 265

The maximum thermal resistance of the heat sink can be seen from the matrix to be 3.8 °C/W.

Important note:

Use a silicone-based heat transfer compound between the heat sink and the thyristor power switch. If you use a heat transfer compound that does not contain silicone, then you have to make sure that the chemical silicone substitute does not attack the Noryl SE 1 GFN 1 of the plastic housing. We recommend the use of silicone-based heat transfer compounds, e.g. Dow Corning.

To ensure safe operation at maximum performance, it is essential to strictly observe the thermal requirements according to the derating tables.

TYA 432-45/25, 265

Load current [A]	Thermal resistance [°C/W]						Power loss [W]
	20	30	40	50	60	70	
25.0	2.70	2.34	1.98	1.61	1.25	0.89	28
22.5	3.10	2.69	2.28	1.86	1.45	1.04	24
20.0	3.61	3.13	2.65	2.18	1.70	1.23	21
17.5	4.26	3.70	3.14	2.59	2.03	1.47	18
15.0	5.14	4.47	3.80	3.14	2.47	1.80	15
12.5	6.38	5.56	4.73	3.91	3.09	2.27	12
10.0	8.25	7.19	6.14	5.08	4.02	2.97	9
7.5	11.4	9.94	8.49	7.04	5.59	4.14	7
5.0	17.7	15.4	13.2	11.0	8.74	6.51	4
2.5	-	-	-	-	18.2	13.6	2

T_A
Ambient temperature [°C]

TYA 432-45/50, 530

Load current [A]	Thermal resistance [°C/W]						Power loss [W]
	20	30	40	50	60	70	
50.0	1.03	0.86	0.70	0.53	0.37	0.20	61
45.0	1.27	1.09	0.90	0.71	0.52	0.33	53
40.0	1.54	1.32	1.10	0.89	0.67	0.45	46
35.0	1.85	1.59	1.34	1.08	0.82	0.57	39
30.0	2.26	1.95	1.65	1.34	1.03	0.72	33
25.0	2.85	2.47	2.08	1.70	1.32	0.94	26
20.0	3.73	3.24	2.75	2.26	1.77	1.27	20
15.0	5.22	4.54	3.86	3.19	2.51	1.83	15
10.0	8.21	7.16	6.11	5.05	4.00	2.95	10
5.0	17.2	15.0	12.9	10.7	8.51	6.33	5

T_A
Ambient temperature [°C]

Thermal resistance junction-environment, R_{thja}	< 20.0	°C/W
Thermal resistance junction-baseplate, R_{thjc}	< 0.80	°C/W
Thermal resistance baseplate-heat sink, R_{thcs}	< 0.20	°C/W
Max. permissible baseplate temperature	100	°C
Max. permissible junction temperature	125	°C

Thermal resistance junction-environment, R_{thja}	< 20.0	°C/W
Thermal resistance junction-baseplate, R_{thjc}	< 0.50	°C/W
Thermal resistance baseplate-heat sink, R_{thcs}	< 0.20	°C/W
Max. permissible baseplate temperature	100	°C
Max. permissible junction temperature	125	°C

Connection

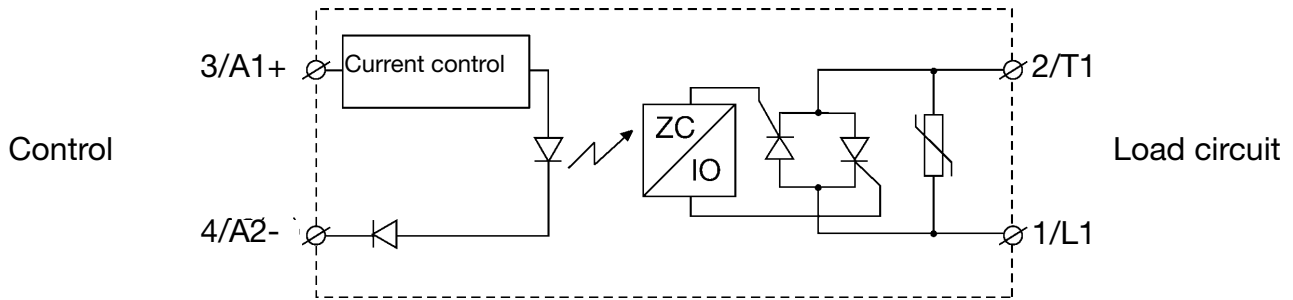

Dimensions

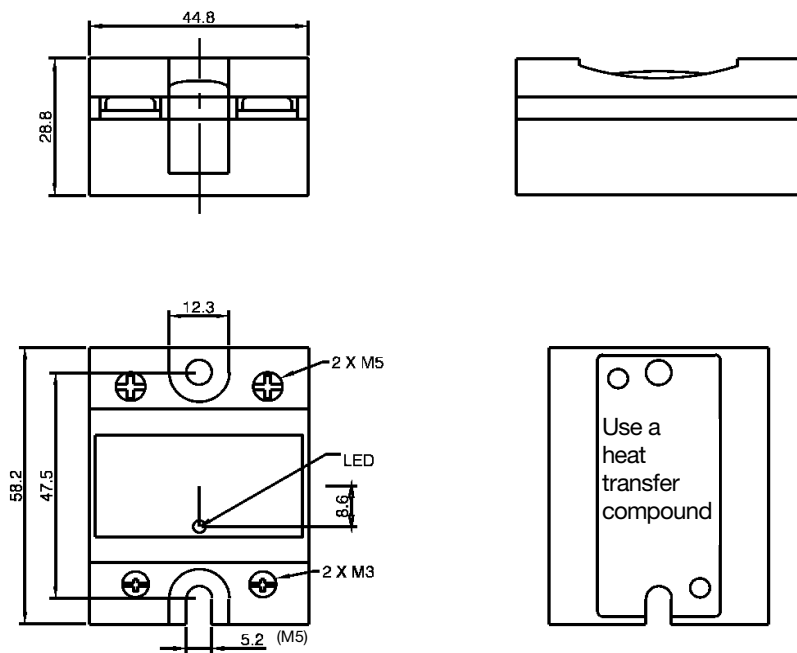

Order details

Type	Load voltage	Load current	Sales No.
TYA 432-45/25, 265	24 – 265V _{rms}	25A _{rms}	70/00408536
TYA 432-45/50, 530	42 – 530V _{rms}	50A _{rms}	70/00408537

In order to ensure fault-free operation as well as higher reliability when using thyristor power switches, we recommend the use of fuses with a superior breaking capacity (e. g. from Ferraz).