

Delivery address: Mackenrodtstraße 14,
36039 Fulda, Germany
Postal address: 36035 Fulda, Germany
Phone: +49 (0) 661 60 03-0
Fax: +49 (0) 661 60 03-5 00
E-Mail: mail@jumo.net
Internet: www.jumo.de

JUMO House
Temple Bank, Riverway
Harlow, Essex CM20 2TT, UK
Phone: +44 (0) 12 79 63 55 33
Fax: +44 (0) 12 79 63 52 62
E-Mail: info@jumoinstruments.fsnet.co.uk

735 Fox Chase
Coatesville PA 19320, USA
Phone: 610-380-8002
1-800-554-JUMO
Fax: 610-380-8009
E-Mail: info@JumoUSA.com
Internet: www.JumoUSA.com



Pressure transmitter JUMO dTRANS p02

Type 404385

General application

The pressure transmitter Type JUMO dTRANS p02 is used to measure the gauge (relative) and absolute pressures of corrosive and non-corrosive gases, vapours and liquids. The measuring device for the pressure transmitter is a piezo-resistive element or thin-film strain gauge. The output signal is a proportional DC current which is linearly proportional to the input pressure. In the version with Protection EEx ia IIC, the pressure transmitter can be mounted within the hazardous Zone 1, for connection to Zone 0. For special applications, e.g. for measuring highly viscous media, the JUMO dTRANS p02 is available with flush pressure connections in various styles. Suitable pressure connections are also available for applications involving media temperatures of up to 200°C.

The display visualises

- the pressure in 13 different units, measurement in % or scaled with a freely adjustable dimensional unit, output current in mA
- the sensor temperature in °C
- measurement error, out-of-range measurement
- minimum and maximum pressures (peak-reading indicator)
- pressure and sensor temperature can be displayed simultaneously (on two lines)

The operating keys can be used to set

- start and end of range with pressure input
- start and end of range without pressure input (blind setting)
- damping or time constant
- current generator function
- output signal on error
- key inhibit
- reset minimum and maximum measured value (peak-reading indicator)
- density correction for different media being measured
- display of the temperature of the medium, in °C or °F

The pressure transmitter JUMO dTRANS p02 can also be operated using a HART® communicator or a PC in connection with a HART® modem and the JUMO setup program running under Windows®.



Accessories

Setup program

Sales No. 40/00365072

The setup program for all instruments in the JUMO dTRANS p02 series has been created according to the VDI/VDE 2187 user interface. In conjunction with the HART® modem, the program enables convenient operation and parameter setting of the pressure transmitter from a PC.

HART® modem

Sales No. 40/00345666

The HART® modem is used to link the JUMO dTRANS p02 pressure transmitter to the serial interface of a PC.

Pressure separator

for adaptation to special situations where the usual pressure connections cannot be used. See Data Sheets 40.9770 to 40.9786.

Isolated supply for Ex applications, HART®-capable

Sales No. 40/00389710,
See Data Sheet 40.4757

Technical data

Explosion protection

To EN 50 014 and EN 50 020 (CENELEC) tested in accordance with directive 94/9/EC (ATEX 100a)
Protection EEx ia IIC T4-T6,
Class 1/2G (use in Zone 1 for connection to Zone 0)
PTB 98 ATEX 2194
The supply must be intrinsically safe and must not exceed the following maximum values:
 $U_i =$ DC 30V
 $I_i =$ 100mA
 $P_i =$ 750mW

Reference conditions

to DIN 16 086 and IEC 770/5.3

Nominal ranges

see ordering details

Range setting

The measurement range can be set from the transmitter keys, by using the setup program or a HART® communicator as described below:

Start and end of range can be continuously adjusted within the nominal range. The span should not be less than 10% of the nominal range..

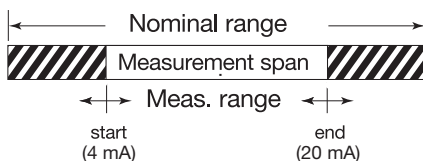

Units that can be visualised

Input pressure:
in mH₂O, inH₂O, inHg, ftH₂O, mmH₂O, mm-Hg, psi, bar, mbar, kg/cm², kPa, Torr, MPa
Measurement:

in %, or scaled with a freely adjustable dimensional unit

Output current:
in mA

Additional displays

Indication of the sensor temperature, minimum pressure, maximum pressure, indication of overrange and on error

Density correction

adjustable within the range from 0.100 to 5.000 kg/dm³

Overload limit

to DIN 16 086
-1 bar and 4 x full scale or
-1 bar and 2 x full scale with ranges \geq 100bar

Bursting pressure

to DIN 16 086
10 x full scale; 2 000bar max.

Parts in contact with the medium

standard:
stainless steel, Mat. Ref. 1.4435, 1.4571
for range \geq 100bar
stainless steel, Mat. Ref. 1.4571, 1.4542

Pressure connection

see ordering details

Output

4 – 20mA max. burden ($U_B = 11.5V$) / 22mA
burden with HART® 1100 Ω max., 250 Ω min.
with HART® protocol V 5.3.
Complies with the guidelines of the HCF (HART® Communication Foundation)

Burden error

< 0.1%

Zero offset / adjustment accuracy

\leq 0.01 mA

Ambient temperature error

within range -20 to +85°C
(compensated temperature range)

zero: 0.005%/°C typical,
0.01%/°C max.

span: 0.005%/°C typical,
0.01%/°C max.

Deviation from characteristic

for limit setting:
not exceeding 0.1% of full scale of nominal range; to DIN 16 086

Hysteresis

For nominal ranges \geq 100bar
 \leq 0.05% of full scale; to DIN 16 086
For nominal ranges \leq 25bar
 \leq 0.02% of full scale; to DIN 16 086

Repeatability

For nominal ranges \geq 100bar
 \leq 0.05% of full scale; to DIN 16 086
For nominal ranges \leq 25bar
 \leq 0.02% of full scale; to DIN 16 086

Response time

approx. 150msec, without damping

Damping

adjustable 0 to 100 s

Stability per year

\leq 0.1% of full scale (for nominal range with reference conditions to IEC 770)

Supply

11.5 – 36V DC
11.5 – 30V DC (for intrinsically safe version)
Supply units for output signal transmission with or without HART® communication, in intrinsically safe version, see Data Sheet 40.4757.

Note:

at least 17V DC (250 Ω) for communication via HART® protocol.

Supply voltage error

\leq 0.1% of full scale per 10V change
(nominal supply voltage 24V DC)

Permitted ambient temperature

-40 to +85°C; to DIN 16 086
(the LCD display cannot be read at temperatures below -20°C)

in intrinsically safe version:

+85°C with temperature class T4
+75°C with temperature class T5
+60°C with temperature class T6

Storage temperature

-40 to +85°C

Permitted temperature of medium

-40 to +120°C for the standard version
-40 to +200°C for basic type extension 4 "for increased media temperatures ..."
-40 to +85°C with halogenized filling oil

Electromagnetic compatibility

Electrostatic discharge:

IEC 1000-4-2 / EN 61 000-4-2
 \pm 4kV contact and \pm 8kV air discharge
 \pm 6kV contact discharge to NAMUR

Electromagnetic fields:

IEC 1000-4-3 / EN 61 000-4-3
frequency range 80 – 1 000MHz,
test field strength 10V/m, 80% AM (1kHz)
ENV 50204
900MHz \pm 5MHz, 10V/m,
50% PM (200Hz)

Transient disturbance (burst):

IEC 1000-4-4 / EN 61 000-4-4
 \pm 2kV, 1 minute with capacitive coupling

Immunity to surge voltage:

IEC 1000-4-5 / EN 61000-4-5 \pm 1kV symmetrical and \pm 2kV asymmetrical

Immunity to conductor-borne interference, induced by high-frequency fields:

IEC 1000-4-6 / ENV 50141
frequency range 0.15 – 80MHz, test voltage 10V, 80% AM (1kHz)

frequency range 0.009 – 80MHz to NAMUR
The pressure transmitter meets all the requirements of EN 50 081, EN 50 082, EN 55 011, EN 55 022 (CE mark) for use in industrial areas.

Interference emission

EN 55 011, Class B, meas. distance 10m
frequency range 30 – 230MHz dB μ V/m;
230 – 1000MHz dB μ V/m quasi-peak value

Mechanical shock

50g/11msec

Mechanical vibrations

5g max. at 10 – 2000Hz

Protection

with connecting cable
IP65 to EN 60 529

Isolation resistance

100M Ω ; 50V DC

Breakdown strength

\geq 500V_{eff.}

Housing

aluminium die-casting GDAISi12

Climatic conditions

\leq 80% rel. humidity annual mean,
with condensation

Electrical connection

clamping case with screw cover, 2-pole and earth terminal, plastic cable gland M20 x 1.5 for cable cross-section 6 to 12mm

Nominal position

factory set upright vertical
(pressure connection below)
operating position is unrestricted

Weight

approx. 1.3kg

HART® communication

between PC and transmitter

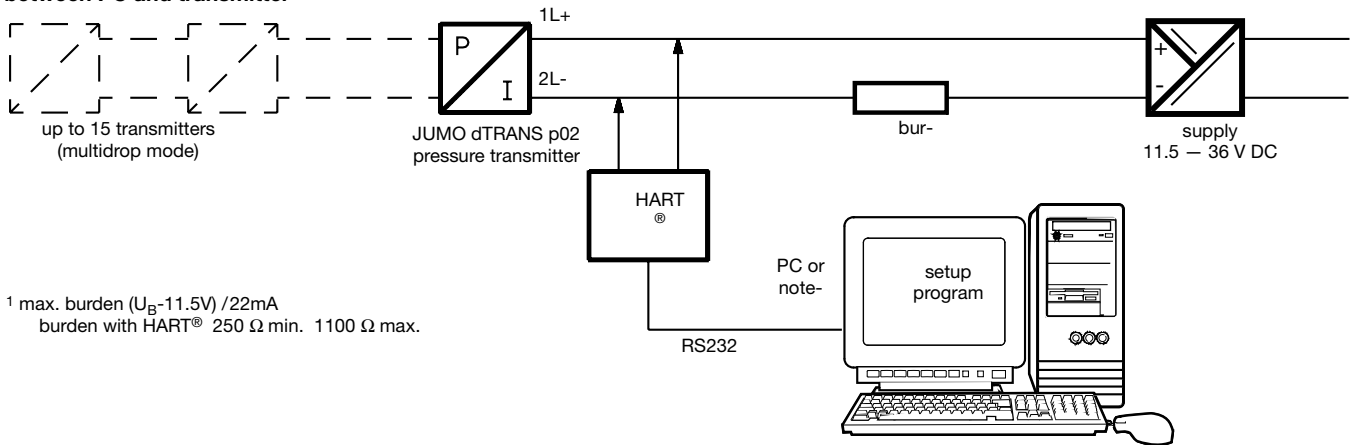

¹ max. burden (U_B -11.5V) / 22mA
burden with HART® 250 Ω min. 1100 Ω max.

between HART® communicator and transmitter

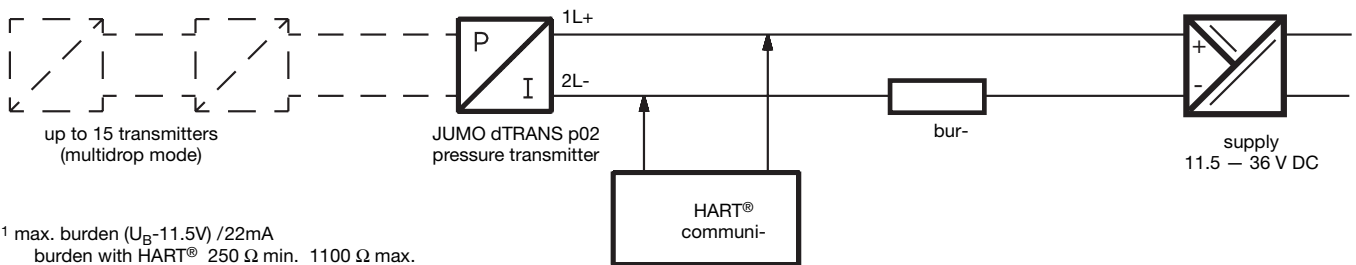

¹ max. burden (U_B -11.5V) / 22mA
burden with HART® 250 Ω min. 1100 Ω max.

Dimensions

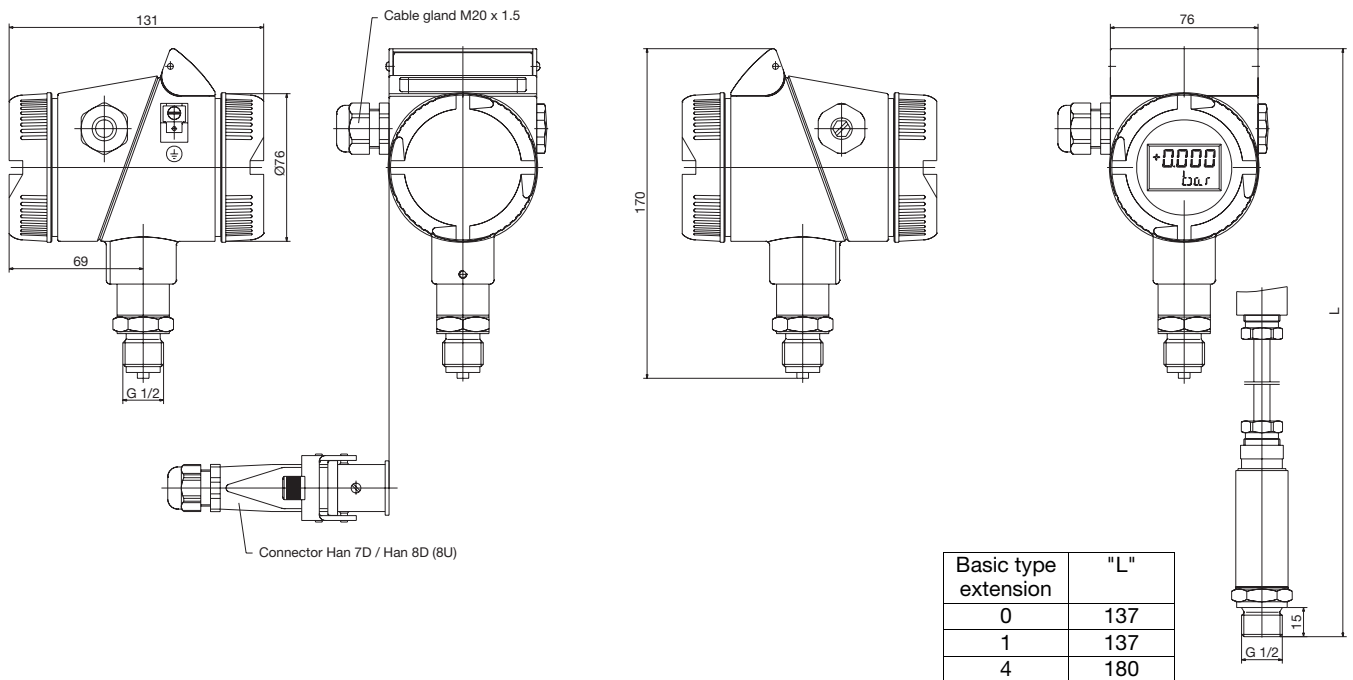

Front-flush pressure connections

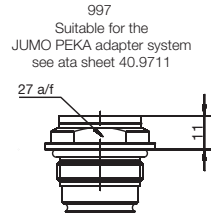
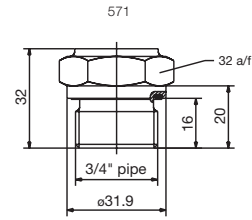
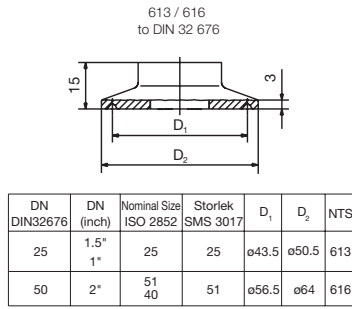
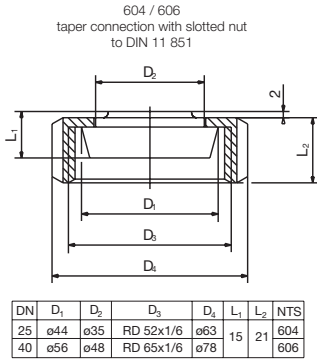

Pressure connections, not Front-flush

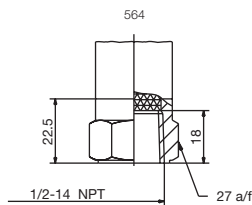
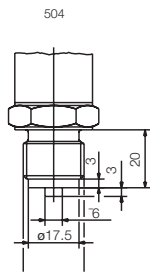
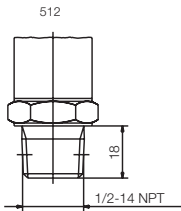

Electrical connection

Connection		Terminals
Supply 11.5 – 36 V 11.5 – 30 V DC for intrinsically safe version		1 L+ 2 L-
Output 4 – 20 mA 2-wire		1 L+ proportional current 4 – 20 mA 2 L- in supply
Test connection Current output	internal resistance of the ammeter ≤ 10 Ω	TEST + TEST -
Test connection HART®		TEST + HART®
Potential equilibration (for intrinsically safe circuit)		
Screen		

Warning:

Earth the instrument!
(Pressure connection and screen)

Termination

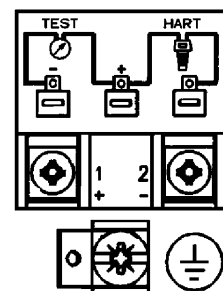

Ordering details

Basic type

404385

JUMO dTRANS p02 pressure transmitter with sensor element in piezo-resistive or thin-film technology

Basic type extensions

- 0 none
- 1 Protection EEx ia II C (PTB 98 ATEX 2194)
- 4 for increased temperature of medium up to 200°C¹ (for process connections 571, 604, 606, 613 and 616 only)^{1, 2}

Nominal range input

- 414 -100 to +100 mbar gauge pressure
- 453 -0.6 to +0.6 bar gauge pressure
- 457 -1 to +4 bar gauge pressure
- 461 -1 to +25 bar gauge pressure
- 464 -1 to +100 bar gauge pressure
- 468 -1 to +600 bar gauge pressure
- 487 -0 to +0.6 bar absolute pressure
- 491 -0 to +4 bar absolute pressure
- 495 -0 to +25 bar absolute pressure

Output

- 405 4 – 20mA with HART® protocol

Process connection

- 504 1/2" pipe to EN 837
- 512 1/2-14 NPT to DIN 837
- 564 1/2-14 NPT internal
- 571 3/4" pipe flush to DIN 837¹
- 604 taper connection with slotted nut DN25 to DIN 11 851^{1,2}
- 606 taper connection with slotted nut DN40 to DIN 11 851^{1,2}
- 613 clamp connection DN 25 to DIN 32 676 ^{1,2}
- 616 clamp connection DN 50 to DIN 32 676 ^{1,2}
- 997 JUMO PEKA ³

Material for process connection

- 20 stainless steel, Mat. Ref. 1.4401
- 82 Hastelloy C276, Mat. Ref. 2.4819
- 99 special material for process connection

Electrical connection

- 06 screw terminals
- 99 special electrical connection

Filling medium for measuring system

- 0 none (only with input for nominal range 464 and 468)
- 1 Silicone oil ¹
- 2 halogenized filling oil¹

404385	/	-	405	-	-	-	-
--------	---	---	-----	---	---	---	---

Ordering code

Factory setting:

please specify the range to be set and the unit in plain text!

¹ not for nominal range -1 to 100 bar and -1 to 600 bar gauge pressure

² not for protection EEx ia II C

³ suitable process connection adapter, see data sheet 40.9711