



2-wire transmitter

for pH Type 202701
for redox Type 202702

General application

The 2-wire transmitter is intended for linking a pH or redox combination electrode with plug connection to indicators/controllers with an active 4–20 mA input. On the output side the 2-wire transmitters have a connection for supply and standard signal. Zero and slope of pH combination electrodes are adjusted at the indicator/controller. No calibration is required for redox electrodes.

The 2-wire transmitter is screwed directly on to the electrode head of the combination electrodes.

This circuit arrangement largely prevents interference from dirt, humidity, or electrical fields from live conductors. A conventional coaxial cable is sufficient as connection between the transmitter and the indicator. This permits trouble-free transmission over larger distances between the transmitter and the indicator.

An isolated supply is recommended when operating the transmitters with a PLC.

Type 202701 for pH

The 2-wire transmitter converts the high-impedance signal of the pH electrode (up to 1000 MOhm) into a standard 4–20 mA signal.

Type 202702 for redox

The 2-wire transmitter converts the signal of the redox electrode into a standard 4–20 mA signal.



Type designation

Type 202701 2-wire transmitter for pH
Type 202702 2-wire transmitter for redox

Accessories

Standard accessory
Operating instructions

Available accessories

- Cable socket N
Type 2991-00-0 5 mm dia.
- Adapter (Sales No. 20/00332273) for testing the signal output of the 2-wire transmitter

Technical data

Type 202701 pH

Input

The high-impedance voltage signal of the pH electrode in the range +600 to –600 mV is converted to a standard 4–20 mA signal (not isolated).

Type 202702 redox

Input

The voltage signal of the redox electrode in the range of –1000 mV to +1000 mV is converted to a standard 4–20 mA signal (not isolated).

general

Case
PVC

Weight

0.2 kg max.

Electrical connection

Input
coaxial connector suitable for most commercially available electrode connector heads

Output
coaxial screw-plug connection suitable for cable socket N

Supply U_B

11.5 to 30 V DC
nominally 24 V DC

Max. current uptake

40 mA approx.

Supply voltage error

0.02% max. of span per Volt deviation from 24 V DC

Output signal

max. burden $\frac{U_B - 11.5V}{0.02A}$

Deviation of characteristic

2.5 % max. referred to span

Ambient temperature error

0.2% max. per 10 °C referred to span

Burden error

0.02% max. of span per 100 Ohm burden

Permitted ambient temperature

–5 to +55°C

Protection

IP65 to EN 60 529

CE symbol

EN 50 081 Part 1
EN 50 082 Part 2

Dimensions

diameter 20 mm approx.
length 145 mm approx.

Block diagram

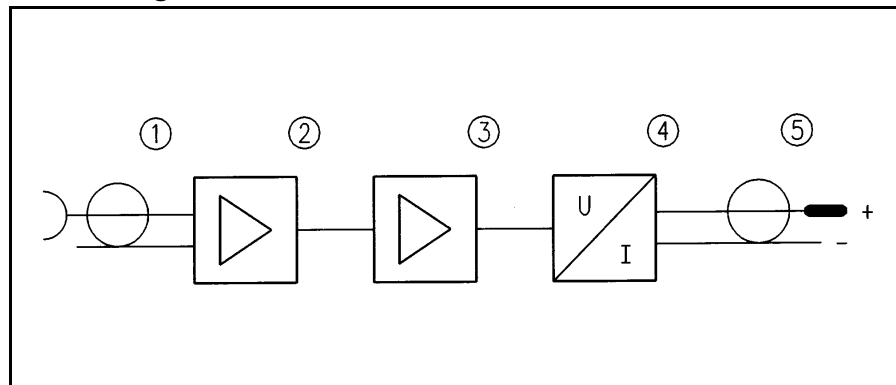

Connections

Coaxial plug
 outer sleeve -
 inner pin +

Coaxial cable
 screen -
 inner conductor +

The current 4 – 20 mA in the output circuit provides the supply to the 2-wire transmitter (4mA) and the output signal (4 – 20 mA).

Supply units suitable for the 2-wire transmitter:

e.g. supply units to Data Sheet 40.9750, if no isolation is required, or supply units to Data Sheet 95.6055 when isolation is necessary.

Operation

The combination electrode is connected to the cable socket N (1). The input voltage is passed to the amplifier (2). Stage (3) determines the start and end of the signal assignment. Stage (4) converts the voltage into a proportional 4 – 20 mA current. The connector N (5) connects the 2-wire transmitter to the next instruments.

Example 1:

Possible arrangement of a complete measurement circuit:

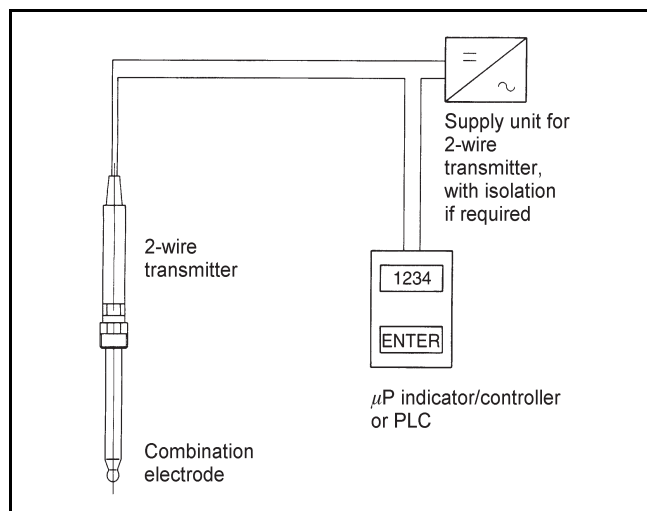

Example 2:

Possible arrangement of a complete measurement circuit for determining electrode parameters, with adapter and multimeter:

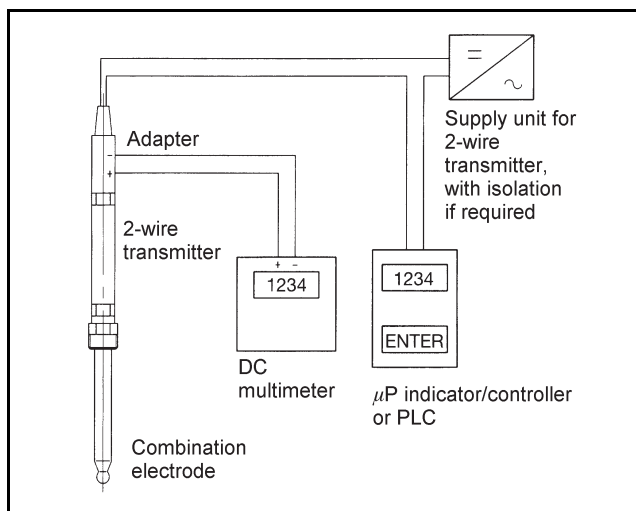

Stock items

(delivery 3 working days after receipt of order)

Type	Sales No.
202701	20/00332272
202702	20/00335049

Non-stock items

(delivery 2 weeks after receipt of order)

Type	Sales No.
202701 (with M12 connector)	20/00409877
202701 (with M12 connector / Measuring range -600...+600 mV)	20/00415579