

Delivery address: Mackenrodtstraße 14,  
36039 Fulda, Germany  
Postal address: 36035 Fulda, Germany  
Phone: +49 661 6003-0  
Fax: +49 661 6003-607  
E-mail: mail@jumo.net  
Internet: www.jumo.net

JUMO House  
Temple Bank, Riverway  
Harlow, Essex CM 20 2TT, UK  
Phone: +44 12 79 63 55 33  
Fax: +44 12 79 63 52 62  
E-mail: sales@jumo.co.uk  
Internet: www.jumo.co.uk

885 Fox Chase, Suite 103  
Coatesville PA 19320, USA  
Phone: 610-380-8002  
1-800-554-JUMO  
Fax: 610-380-8009  
E-mail: info@JumoUSA.com  
Internet: www.JumoUSA.com



# JUMO dTRANS Rw 01 µP transmitter / controller for high-purity water

## Type 202545 Panel-mounting housing to DIN 43 700

### Brief description

This instrument, with a 96mm x 48mm bezel size and a plug-in controller module, measures and controls the resistance / conductivity of high-purity water. The instrument has been designed to meet the special requirements of high-purity water measurement.

The transmitter has two analog and two logic inputs. The first analog input is suitable for connecting 2-electrode measuring cells with cell constants of 0.01 or 0.1 [1/cm]. The second analog input can be used to connect Pt100 or Pt1000 resistance thermometers.

The instrument features two 4-digit 7-segment displays for indicating the resistance / conductivity (red) and the temperature (green). During programming, the displays provide comments on the inputs.

A great variety of control tasks can be handled by the various output options (relay contacts and / or analog outputs). The two relay "make" contacts that are provided on the instrument as standard can be configured as a limit controller and / or pulse width or pulse frequency controllers, or as a modulating controller. To obtain analog controller outputs, the optional analog outputs must be configured accordingly.

All controller outputs can be configured for a P, PI, PD or PID control action.

In the basic version, the instrument provides two relay "make" contacts and one logic output (0/5V). Two additional outputs can be, according to choice, fitted as relay changeover contacts and / or analog outputs (process value output or analog controller output) or as a serial interface (Profibus-DP or MODbus / Jbus protocol).

For further information on "De-ionized and high-purity water" see page 7.

### Block structure

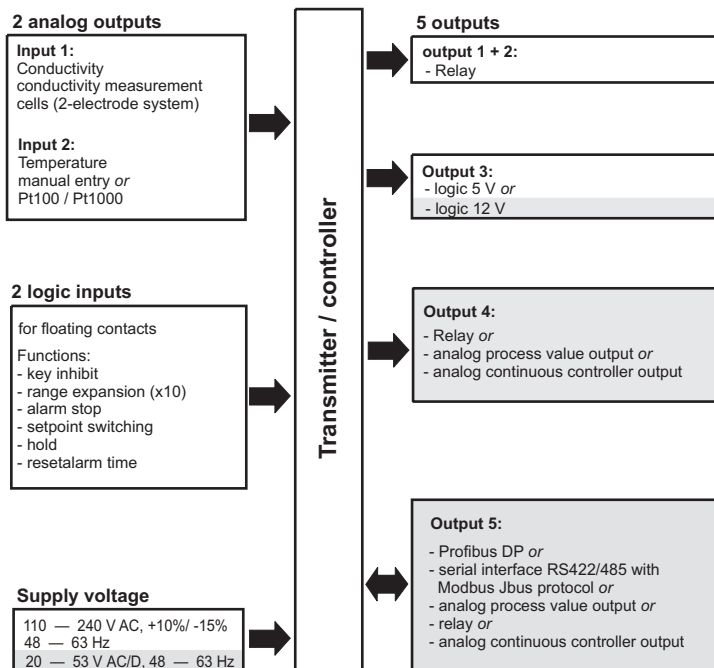

☐ extra codes / options



Type 202545 / ...



Type 202545 / .../640

### Special features

- Temperature compensation as per **ASTM D-1125-95\***.
- Fulfils the requirements of **USP**.
- Additional linear compensation is possible.
- Display of uncompensated conductivity is possible.
- Compact design, only 96 x 48 x 110 mm.
- Monitoring of the medium temperature is possible.
- 2 electrically isolated analog process outputs 0(4) — 20 mA / 0(2) — 10 V, freely selectable and scalable for conductivity or temperature (option).
- 2 relays as standard, freely programmable as limit controller or P, PI, PID, PD controller with pulse width / pulse frequency output or modulating controller.
- 1 logic output (alarm contact or temperature limit contact).
- Front protection IP 65.
- IP65 surface mounting or site housing on request.

\* see page 7.

### Zulassungen



## Operation

For easy programming and operation, the controller parameter and configuration data are assigned to various levels.

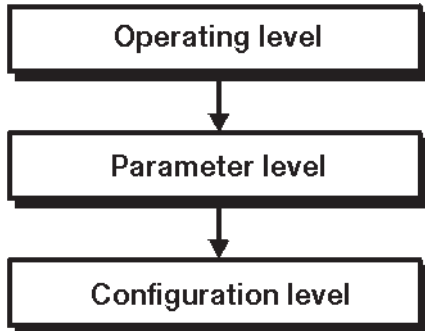

Code words protect the levels from unauthorized access.

Membrane keys ensure simple and user-friendly operation.

The two LED displays show the parameter symbols and the corresponding values.

### Operating level

The lower display, for example, shows the symbol, the upper display shows the corresponding value. Setpoints SP1 and SP2 can be altered by using the membrane keys.

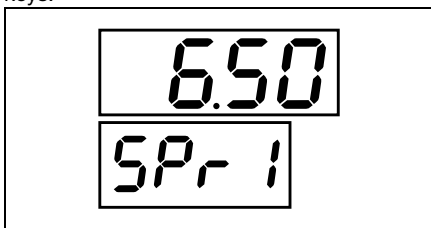

### Parameter level

The controller is adapted to the control loop at this level. The appropriate parameters appear here, with symbol and value. Only those parameters will be indicated which correspond to the configuration of the controller (configuration level).

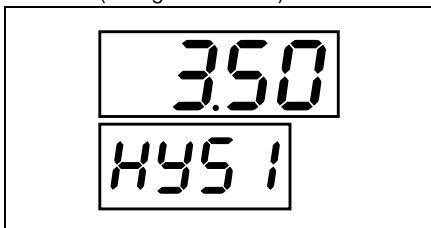

### Configuration level

This level is used to adapt the controller to the control task, or for adaptation of the inputs and outputs.

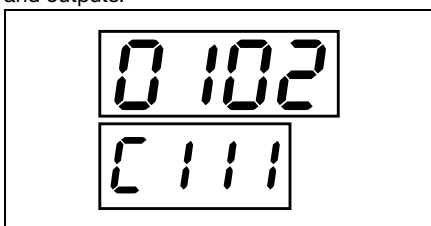

## Indications / controls

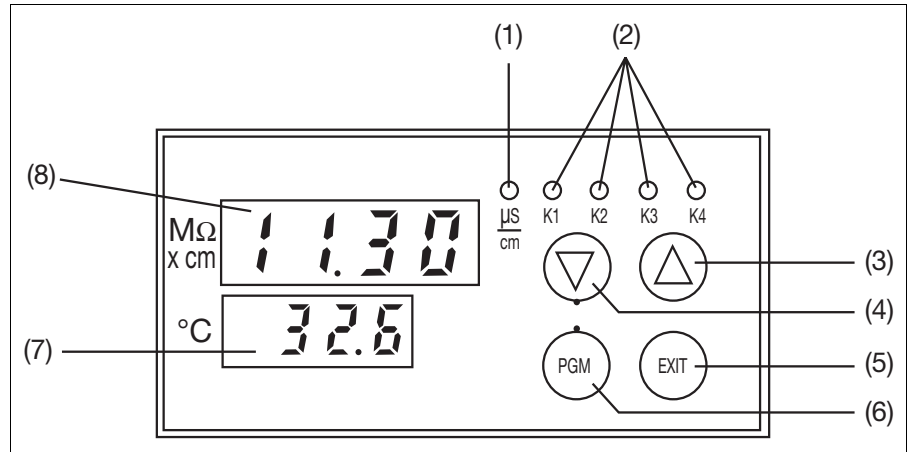

(1) LED display in $\mu\text{S}/\text{cm}$	(6) PGM key for selection of parameters and confirmation of entries
(2) Status indicators (yellow) for outputs 1 to 4	(7) 4-digit temperature display (green), 8 mm high
(3) Increment key for altering parameters or manual operation of relay K2	(8) 4-digit process value indication (red) 13 mm high
(4) Decrement key for altering parameters or manual operation of relay K1	(4) "CAL": Initiates calibration (relative cell + constant $K_{\text{rel}}$ or temperature coefficient $\alpha$ )
(5) EXIT key to leave the levels	(3) + (5) Initiate manual operation or hold

### Additional functions of the JUMO dTRANS Rw 01

#### Calibration of the cell constant

Subject to manufacturing tolerances, the cell constant of the measuring cell may deviate slightly from its nominal (printed) value. In addition, the cell constant may change during operation (due to deposits, for example). This results in a change of the output signal from the cell. The dTRANS Rw 01 offers the user the possibility of compensating any deviation from the nominal value of the cell constant through **manual entry** (range 80 – 120%) or **automatic calibration** of the relative cell constant  $K_{\text{rel}}$ .

#### For enhanced requirements

High-purity water measuring cells can be supplied together with a test report which states the precise cell constant that was measured. This value is set on the transmitter (**manual entry**). The combination high-purity water transmitter and measuring cell has thus been harmonized and is ready for operation.

#### Calibrating the temperature coefficient $\alpha$

The conductivity of high-purity water is strongly dependent on the temperature. To ensure correct measurement, it is therefore necessary to know both the temperature and temperature coefficient  $\alpha$  [% per  $^{\circ}\text{C}$ ] of the measuring solution. The temperature can either be measured automatically, with a Pt100 or Pt1000 temperature probe, or set manually by the user. The transmitter provides

various possibilities for compensating the temperature:

- according to ASTM D-1125-95 (standard setting)
  - automatic temperature compensation
  - choice of either "neutral contamination with NaCl" (standard)
    - or "alkaline contamination with NaOH"
    - or "acidic contamination with HCl"
- linear temperature compensation
  - automatic determination of the temperature coefficient
  - or manually, within the range (0 – 20% per  $^{\circ}\text{C}$ )

#### Programmable response of the process value output to underrange / overrange

On underrange or overrange, the process value output can move to the following operational states:

-4%, 0%, 100% or 110% freely selectable

**Example:** The instrument is program-med to 4 – 20 mA, corresponding to 0 – 2  $\mu\text{S}/\text{cm}$

The instrument can be set up so that, on exceeding 2  $\mu\text{S}/\text{cm}$ , the output signal 20 mA (100 %) is either maintained or will jump to 22 mA (110 %). The 22 mA value can then be recognized as "irregular" by a connected PLC.

#### Bilinear output

This function divides the signal for the analog process value output into two linear portions (0 – 50% and 50 – 100% of the output

signal), with a knee-point at 50% of the output signal. The knee-point of the characteristic can be shifted along the dotted 50% line. The factory setting of 50% produces a straight-line characteristic.

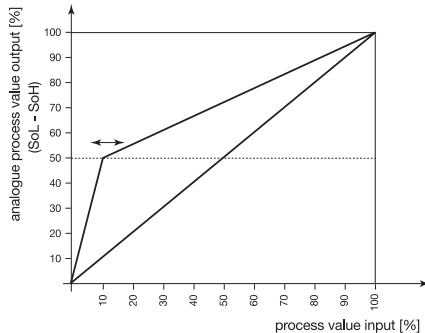

The bilinear characteristic is used when the "normal" measurement range is likely to be frequently exceeded.

Example: The normal measurement range spans 0 – 2 µS/cm.

However, measurements of up to 8.0 µS/cm can also occur.

In this case, the range 0 – 10 µS/cm will be selected, and the knee-point set at 20% of this range (20% of 10 µS/cm corresponds to 2 µS/cm).

This results in measurements in the range 0 – 2 µS/cm being converted into an output signal 0 – 10 mA. Measurements in the range 2 – 10 µS/cm will be converted into an output signal 10 – 20 mA.

❑ **The response of the controller relays to "Hold" can be defined**

"Hold" is initiated either manually, using the keys, by a logic input, or by an alarm event. The outputs of the relays K1 and K2 can move to the following (programmable) states on "Hold":

0%	Relay de-energized
50% output	For dynamic controllers, 50% of the maximum pulse width or frequency is produced
100% output	Relay is energized, or maximum pulse width / frequency
Output accepted	The present output continues to be produced

❑ **In "Manual" mode, the relays K1 and K2 are operated manually, by using the keys.**

Either key or switch operation can be selected, by a setting at the parameter level.

Key operation: The relay is switched as long as the key is pressed (e.g. for manual dosing).

Switch operation: The first key stroke switches the relay on – the second switches it off again (toggle action), e.g. for emptying large tanks.

❑ **Simulation of the analog process value output**

In the manual mode, the process value output (0/2 – 10 V or 0/4 – 20 mA, depending on the setting) can be switched in 10% steps from 0 – 100%.

Application: "Dry-run" commissioning of the plant (without measuring cell, fault search, servicing).

❑ **Controller output functions**

Output 1 (relay): Switching, with pulse frequency or pulse width action / limit monitoring / switched off. Switching function can be reversed. MAX / MIN limit comparator.

Output 2 (relay): Switching, with pulse frequency or pulse width action / limit monitoring / MAX / MIN limit comparator for temperature / switched off. Switching function can be reversed. MAX / MIN limit comparator.

Output 3, relay or analog process value output: "Hold" / alarm pulse contact; alarm steady contact / MAX limit comparator for temperature input / MIN limit comparator for temperature input / output of resistance process value (only for analog process value output) / output of temperature process value (only for analog process value output) / analog controller output (only for analog process value output) / no function.

Output 4, logic output: "Hold" / alarm pulse contact / alarm steady contact / MAX / MIN limit comparator for temperature input / no function.

Output 5, relay or analog process value output: "Hold" / alarm pulse contact; alarm steady contact / MAX limit comparator for temperature input / MIN limit comparator for temperature input / output of resistance process value (only for analog process value output) / output of temperature process value (only for analog process value output) / analog controller output (only for analog process value output) / no function.

**Limit comparator (limit monitor)**

Controller outputs 1 to 5 (depending on the instrument version) can be assigned to a limit-monitoring function.

For each one, the direction of switching (i.e. on going above, or going below a limit), pull-in and / or drop-out delay, and a hysteresis can all be defined.

**Interface**

The microprocessor / controller can be optionally fitted with an RS422 / RS485 interface. This is used for communication with higher-level systems and integration into a data network. The transmission protocol can be either Profibus-DP or MODbus/Jbus.

**Technical data**

**Inputs**

**Analog input 1**

Measuring cells with cell constants 0.01 or 0.1 [1/cm] (2-electrode principle). The cell constants can be adjusted over a range 80 – 120%.

**Lead compensation, input 1**

The influence of long cables can be compensated by entering the lead resistance, in the range 0.00 to 9.99 Ω.

**Analog input 2**

Resistance thermometer Pt100 or Pt 1000, in 2- or 3-wire circuit -50 to +250°C

Measurement display in °C or °F (option)

**Lead compensation, analog input 2**

The lead resistance can be compensated in software by a correction of the process value. This is not required if the resistance thermometer is connected in a 3-wire circuit. When a resistance thermometer is connected in a 2-wire circuit, lead compensation can be provided by using an external compensation resistor.

**Functional description of logic inputs 1 and 2**

The two standard logic inputs can be operated by floating contacts (relays) from a PLC, or by switches. The following functions can be selected and assigned:

Key inhibit: The PLC or a key switch can be used to lock the keys on the transmitter, to prevent unauthorized entries being made.

Setpoint changeover: For comfortable process control. As long as the logic input is not operated, setpoint pair SPR1 and SPR2 is active. If the appropriately configured logic input is operated, then the second setpoint pair is activated (setpoint switching).

Freeze measurement: The indicated measurement and the process value output no longer change.

"Hold": This function can be used (for instance, by a supervisory PLC) to put the instrument into the secure "Hold" state. The response of the controller to "Hold" is as previously defined.

"Hold reversed": The same function as for HOLD, but when the logic input is open.

Alarm stop: The alarm generation via the configured output is reset or prevented, but the alarm LED (e.g. K4) continues to blink as a warning.

Reset alarm time: The alarm generation via the configured output is prevented. The alarm delay time is set to zero, but is restarted when the logic output becomes inactive and the start conditions are fulfilled once more. The alarm LED (e.g. K4) continues to blink as a warning.

Range expansion (x10): If only a small portion of the measurement range is used, it may be advantageous for the transmitter to react to 0 – 10% of the process value by producing 0 – 100% of the output signal.

**Measurement and control range**

for cell constant 0.01:  
0.5 µS/cm, 2.0 µS/cm, 10.0 µS/cm,  
20 MΩcm

for cell constant 0.1:  
5.0 µS/cm, 20.0 µS/cm

**Deviation from characteristic\***  
≤ 0.25% of measurement range

**Ambient temperature error\***  
≤ 0.15% per 10 °C

**Reference temperature**  
25°C

**Temperature display**  
-50 to +250°C (can be switched to °F)

**Deviation from characteristic**  
≤ 0.25% of measurement range.

**Ambient temperature error**  
≤ 0.1% per 10 °C

**Outputs**

2 relay outputs, 1 logic output, 1 analog process value output or 1 additional relay, and 1 serial interface are available.

**1. Relay, output 1 / 2 (standard)**

Make contact (can also be configured as break contact)  
contact rating: 3A, 250V AC with resistive load.  
contact life  
> 5x10<sup>5</sup> operations at rated load

**2. Logic output, output 4**

0/5V<sub>Rload</sub> ≥ 250Ω (standard)  
0/12V<sub>Rload</sub> ≥ 650Ω (option)

**3. Process value output, output 3 or 5 (option)**

freely configurable:  
0(2) — 10V  $R_{load} \geq 500\Omega$  or  
0(4) — 20mA  $R_{load} \geq 500\Omega$   
electrically isolated from the inputs:  
 $\Delta U \leq 30V$  AC or  
 $\Delta U \leq 50V$  DC.

**Deviation from characteristic of the output signal**  
≤ 0.25% ± 50 ppm per °C

**4. Relay, output 3 or 5 (option)**

(only for instruments without a process value output)  
changeover contact  
contact rating: 3A, 250V AC with resistive load  
contact life:  
> 5 x 10<sup>5</sup> operations at rated load

**5. Interface RS422 / RS485, Output 5 (option)**

electrically isolated

**Baud rate**

4800 / 9600bps

**Protocol**

MODbus/Jbus or Profibus-DP

**General controller data**

**A/D converter**  
resolution > 15 bit

**Controller type**

Outputs 1 and 2  
limit controller, pulse width or pulse frequency controller, modulating controller. Freely configurable and mixable

K3 / K5:  
proportional controller

**Control action**

configurable as P, PI, PID or PD.

**Sampling time**

210msec

**Measurement circuit monitoring**

Input 1: out-of-range  
Input 2: out-of-range, probe short-circuit, probe break  
The outputs move to a defined (configurable) status.

**Data backup**

EEPROM

**Supply voltage**

110 — 240 V AC +10%/-15%,  
48 — 63 Hz or  
20 — 53 V AC/DC, 48 — 63 /0 Hz

**Power consumption**

approx. 8V A

**Electrical connection**

via gold-plated faston connectors to DIN 46 244/A;  
4.8mm x 0.8mm

**Permissible ambient temperature**

0 to +50°C

**Permissible ambient temperature limits**

-10 to +55°C

**Permissible storage temperature**

-40 to +70°C

**Climatic conditions**

rel. humidity ≤ 75%, no condensation

**Enclosure protection**

to EN 60 529  
front IP65 / rear IP20

**Electrical safety**

to EN 61 010  
clearance and creepage distances for  
- overvoltage category II  
- pollution degree 2

**Electromagnetic compatibility**

to EN 61 326  
radiated interference: Class B  
interference immunity: to industrial requirements

**Housing**

Panel-mounting housing in conductive plastic to DIN 43 700, base material ABS with plug-in controller module.

**Operating position**

unrestricted

**Weight**

approx. 320g

**Wall-mounting housing (extra code /640)**

approx. 1400 g

**Option****Wall-mounting housing**

extra code /640

On request, the JUMO dTRANS Lf 01 can be supplied built into a surface-mounting housing. The housing is suitable for wall-mounting or for mounting on a 35 x 7.5 mm DIN rail to EN 50 022.

The housing is sturdy and provides IP67 protection for the built-in instrument and is fitted with six cable glands. Unused cable glands can be tightly sealed using the blind grommets that are included in the delivery.

The electrical connection is made via screw terminals (wire cross-section up to 2.5 mm<sup>2</sup>).

**Standard accessories**

- 2 mounting brackets (not with extra code / 640 (wall-mounting housing))
- 1 seal for panel-mounting (not with extra code /640 (wall-mounting housing))
- sundry items for wall-mounting (only with extra code /640 (wall-mounting housing))
- sundry items for DIN rail mounting (only with extra code /640 (wall-mounting housing))
- 1 Operating Manual B 20.2545.0.1

**Optional accessory**

Interface Description B 20.2530.2

\* The errors quoted refer to the specific conductivity

## Parameter

Parameter	Display	Value range	Comments
Alarm tolerance	AL1	0.000 – 9999*	The alarm is only generated when the level (setpoint + alarm tolerance) has been passed, and the alarm delay time has elapsed
Alarm delay	AL2	0 – 6000 sec	Delay time before the alarm contact is activated
Proportional band 1 – Lf	Pb1	1 – 9999*	Influences the P action of the controller
Proportional band 2 – Lf	Pb2		
Derivative time 1	dt1	0 – 9999 sec	Influences the D action of the controller If dt = 0, the controller has no D action.
Derivative time 2	dt2		
Reset time 1	rt1	0 – 9999 sec	Influences the I action of the controller If rt = 0, the controller has no I action.
Reset time 2	rt2		
Minimum ON time 1 (for limit controller or pulse width controller) or minimum pulse width 1 (for pulse frequency controller)	tr1	0.2 – 999.9 sec	Determined by the technical data of the dosing device (solenoid valve, dosing pump)
Minimum ON time 2 (for limit controller or pulse width controller) or minimum pulse width 2 (for pulse frequency controller)	tr2		
Switching differential 1	HYS1	1 – 9999*	Defines the switch-off point for the control contacts
Switching differential 2	HYS2		
Switching differential 3	HYS3		
Switching differential 4	HYS4		
Switching differential 5	HYS5		
Pull-in delay 1	Ond1	0.0 – 999.9 sec	Delay time before the contact is activated
Pull-in delay 2	Ond2		
Pull-in delay 3	Ond3		
Pull-in delay 4	Ond4		
Pull-in delay 5	Ond5		
Drop-out delay 1	Ofd1	0.2 – 999.9 sec	Delay time until the contact moves back to the initial position
Drop-out delay 2	Ofd2		
Drop-out delay 3	Ofd3		
Drop-out delay 4	Ofd4		
Drop-out delay 5	Ofd5		
Maximum pulse frequency 1	Fr1	0 – 150 pulses/min	Maximum frequency of pulses (operating a dosing pump, for instance)
Maximum pulse frequency 2	Fr2		
Cycle time 1	Cy1	2.0 – 999.9 sec	The period in which a pulse is modulated
Cycle time 2	Cy2		
Output level limit, relay 1	Y1	0 – 100%	The maximum output level for a pulse width / pulse frequency controller
Output level limit, relay 2	Y2		
Actuator time	tt	15 – 3000 sec	Modulating controller

\* Decimal point and dimensional unit corresponding to chosen range

# Connection diagram

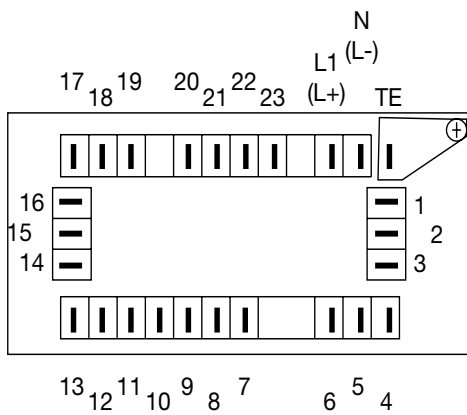

Rear view with faston connectors

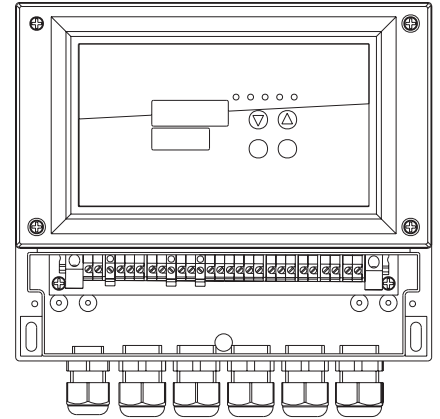

Wall-mounting housing (extra code /640) with terminal strip

Outputs	K	Terminal assignments	Symbol
Relay 1 (K1) Status indication LED K1	1	23 common 22 make (n.o.)	
Relay 2 (K2) Status indication LED K2	2	21 common 20 make (n.o.)	
Relay 3 (K3) Status indication LED K3	3	16 break (n.c.) 15 common 14 make (n.o.)	
or analog process value output (electrically isolated)		15 - 14 +	
Logic output 1 (K4) Status indication LED K4	4	19 - 17 +	
Outputs	K	Terminal assignments	Symbol
Relay 4 (K5) no status indication	5	3 break (n.c.) 2 common 1 make (n.o.)	
or analog process value output (electrically isolated)		2 - 1 +	

Inputs		Terminal assignments	Symbol
Conductivity cell		6 Outer electrode, on coaxial cells 7 Inner electrode, on coaxial cells	
Resistance thermometer in 3-wire circuit		9 10 11	
Resistance thermometer in 2-wire circuit		9 10 11	

Inputs		Terminal assignments	Symbol
Serial interface RS422 (option)	RxD	5 RxD + Receive data 4 RxD -	
	TxD	2 TxD + Transmit data 1 TxD -	
	GND	3 GND	
Serial interface RS485 (option)	+	2 TxD/RxD + Transmit data / receive data	
	-	1 TxD/RxD -	
GND	3 GND		
	Serial interface Profibus-DP (option)	VP 4 supply voltage, positive (P5V) RxD/TxD-P 2 receive/transmit data positive, B conductor RxD/TxD-N 1 receive/transmit data negative, A conductor DGND 3 ground for data transmission	
Logic input 1		13 19	
Logic input 2		12 19	
Supply voltage see nameplate	AC/ DC	AC: L1 phase/line N neutral TE technical earth DC: L + L -	

**Connection for conductivity cell**

	Conductivity cell (JUMO types)		dTRANS Rw 01
	Plug-in head	Fixed cable	
Outer electrode		white	6
Inner electrode	2	brown	7
Temperature compensation	1	yellow	11
	3	green	10
Link			10
			+ 9

## Additional information on “De-ionized and high-purity water”

### De-ionized water

The term “distilled water” is also used in this connection. These terms refer to the production methods that are used. The specific conductivity of de-ionized water lies in the range from approx. 2 to 10 µS/cm at 25°C.

### High-purity water

High-purity water is produced from de-ionized water, using special process steps, and has a specific conductivity of about 0.055 to 2 µS/cm at 25°C. Because of the non-linear characteristic of high-purity water, a specially adapted temperature compensation should be used during measurement. Automatic temperature acquisition or a constant temperature is indispensable for correct temperature compensation.

### Standards and guidelines

In the German-speaking world these include the DIN ISO standard, VDE guidelines, and the “Europäische Arzneibuch” (Ph. Eur.).

Frequently cited standards in the English-speaking world are: the ASTM standard (ASTM = American Society for Testing and Materials) and the USP (The United States Pharmacopeia).

## Dimensions

Type 202540 / ...

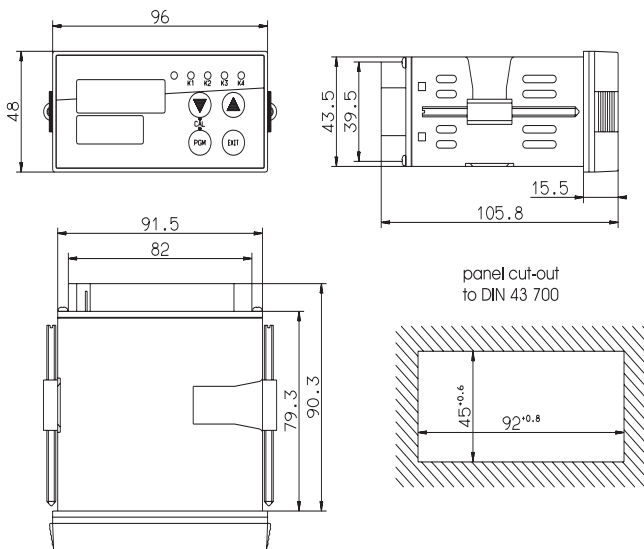

Panel cut-out to DIN 43700  
close mounting (minimum dimensions)

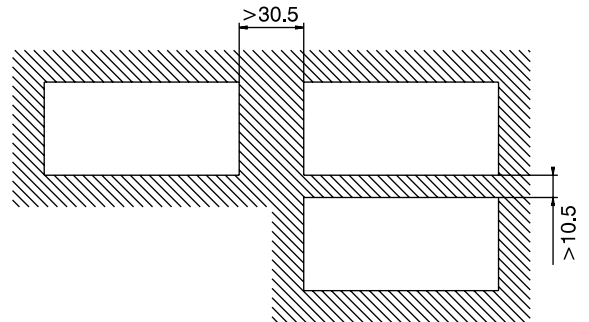

## Option

Surface-mounting housing, extra code /640, IP67 protection

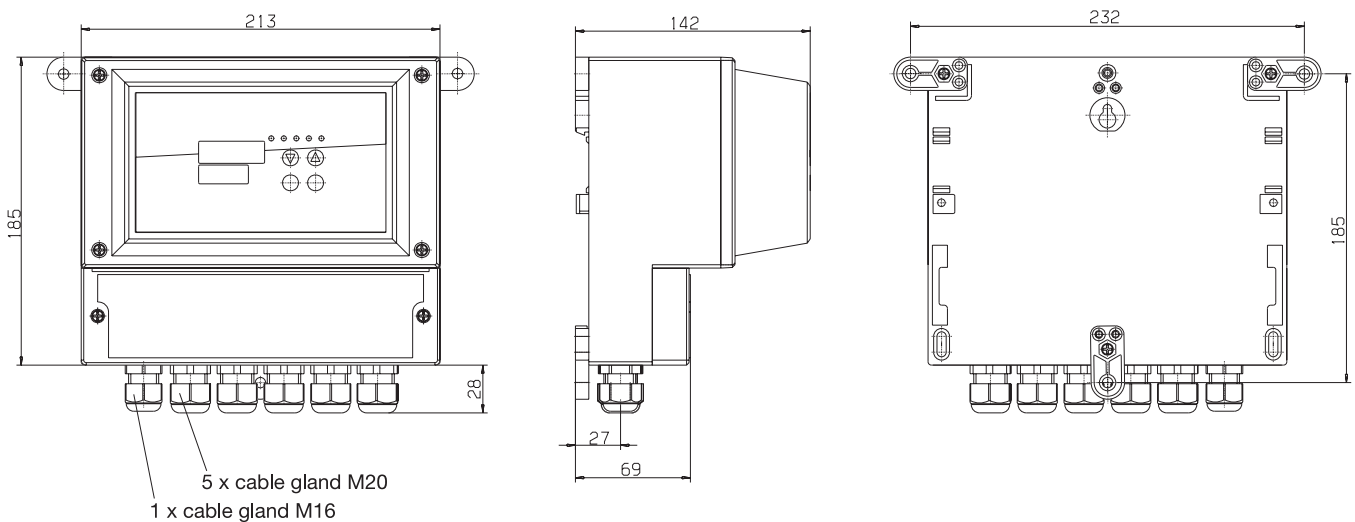

**Type designation**

**(1) Basic type**

202545 JUMO dTRANS Rw 01, microprocessor transmitter/controller for high-purity water

**(2) Basic type extensions**

10 Limit controller\*

**(3) Output I**

000 no output  
 310 relay, changeover contact  
 888 process value output, freely configurable

**(4) Output II**

000 no output  
 310 relay, changeover contact<sup>1</sup>  
 888 process value output, freely configurable<sup>1</sup>

**(5) Supply voltage**

22 20 — 53 V AC/DC, 48 — 63/0 Hz  
 23 110 — 240 V AC +10%/-15%, 48 — 63 Hz

**(6) Interface**

00 no serial interface  
 54 serial interface RS422/485<sup>1</sup>  
 64 serial interface Profibus-DP<sup>1</sup>

**(7) Extra codes**

000 no extra codes  
 015 logic output 0/12 V DC, instead of standard 0/5 V DC  
 640 surface-mounting housing for mounting on wall or DIN rail, IP67 protection

**\*Generally**

on **all** controllers of the 202545 series, the user can freely select the following configurations:

- Controller off
- Limit controller
- Pulse width controller with P, PI, PD, PID control action
- Pulse frequency controller with P, PI, PD, PID control action
- Modulating controller

<sup>1</sup> If output II (4) = "310" or "888" then the interface option (6) is not possible (or the other way round)!

	(1)	(2)	(3)	(4) <sup>1</sup>	(5)	(6) <sup>1</sup>	(7)
<b>Order code</b>	202545	/ 10	-		,		-
<b>Order example</b>	202545	/ 10	- 888	,	000	- 23	- 00 - 000

**Stock items**

<b>Type</b>	<b>Sales No.</b>
202545/10-888,000-23-00/000	20/00377256

**Non stock items**

<b>Type</b>	<b>Sales No.</b>
202545/10-888,000-23-00/640	20/00446471

**Optional accessories 1** available ex-stock

<b>Designation</b>	<b>Sales No.</b>
Surface-mounting housing, no door at front, Type 2 FGE-125-2/125	20/00361257
Surface-mounting housing, door at front, Type 2 FGE-150-2/185	20/00361259

**Optional accessories 2**

<b>Designation</b>	<b>Sales No.</b>
Fixing for DIN rail	70/00375749
Blank cover 96 x 48 mm	70/00069680